

Grooving System

GY Series PSC Holder

New
Products

High-rigidity, High-precision Machining

Extensive modularity enables easy exchanges between many different sizes and types of application by simply changing the blade.



Grooving System

GY Series PSC Holder

Modular GY series blades are easily mounted providing a wide range of machining choices.

Coolant Nozzles with Adjustable Angles

Coolant nozzles mounted on the main body can be adjusted to any desired angle (approx. $\pm 10^\circ$) to supply cutting fluid to the cutting edges efficiently and accurately.

Recommended Maximum Coolant Pressure: 1MPa

Over 100 Types of Modular Blades

External, face and recess machining blades can be used for machining a huge range of applications.



PSC System

The double taper and face contact uses the precision machined polygon geometry to provide high clamping rigidity. In addition it provides accuracy and easy positional repeatability when tool changing.

Installation size DCONMS
PSC40, PSC50, PSC63

Cutting Performance

Comparison of Finished Surfaces when Cross-feed Machining 1045 Carbon Steel

The GY series uses modular blades with short overhang exhibiting excellent rigidity, especially during cross-feed machining.

	GY PSC						GY PSC			Conventional		
	Max.Groove Depth .236 inch						Max.Groove Depth .472 inch			Max.Groove Depth .787 inch		
Depth of Cut inch	.039			.059			.039			.039		
Feed IPR	.012	.010	.008	.012	.010	.008	.012	.010	.008	.012	.010	.008
Machined Surface												
Finished Surface Evaluation	OK	OK	OK	OK	OK	OK	OK	OK	OK	NG	NG	NG
Machining Sound	OK	OK	OK	OK	OK	OK	OK	OK	OK	NG	NG	NG

NG - Displays chatter and vibration

<Cutting Conditions>

Workpiece Material : AISI 1045 ø5.906 inch
 Cutting Width : .118 inch
 Cutting Speed : vc = 590 SFM
 Cutting Mode : Cross-feed Machining
 External Coolant 1 Mpa

Repeat Positional Accuracy with PSC Installation

Accuracy of $\pm 0.079 \mu\text{-inch}$ or less for all 3 axes is achieved when replacing tools.

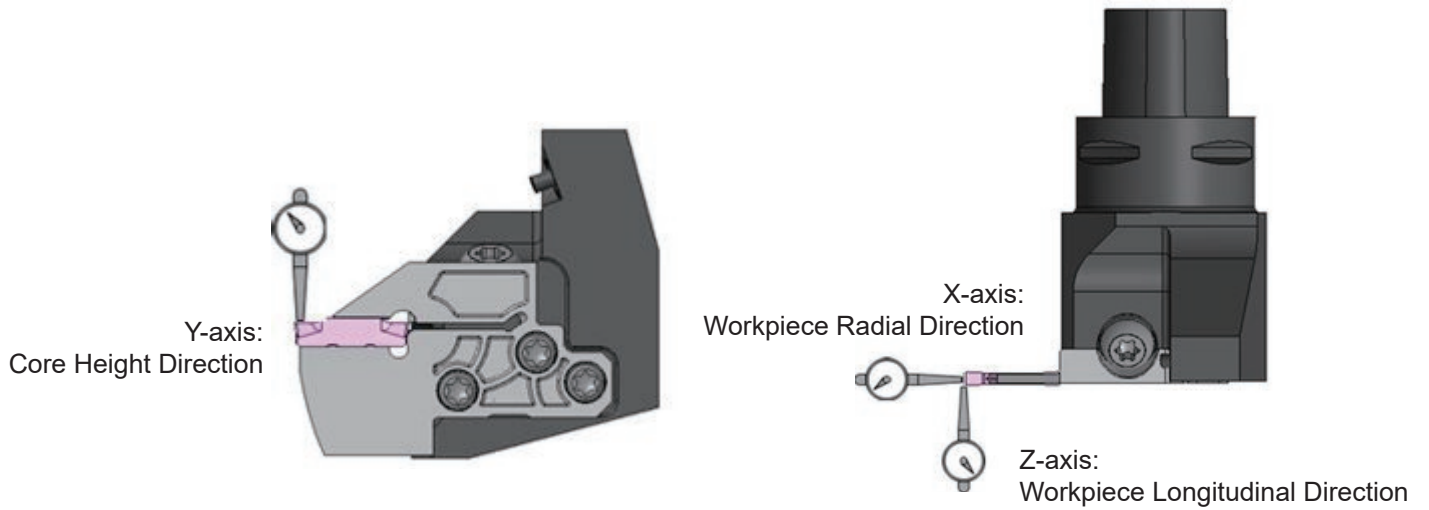

Repeat Positional Accuracy with PSC Installation

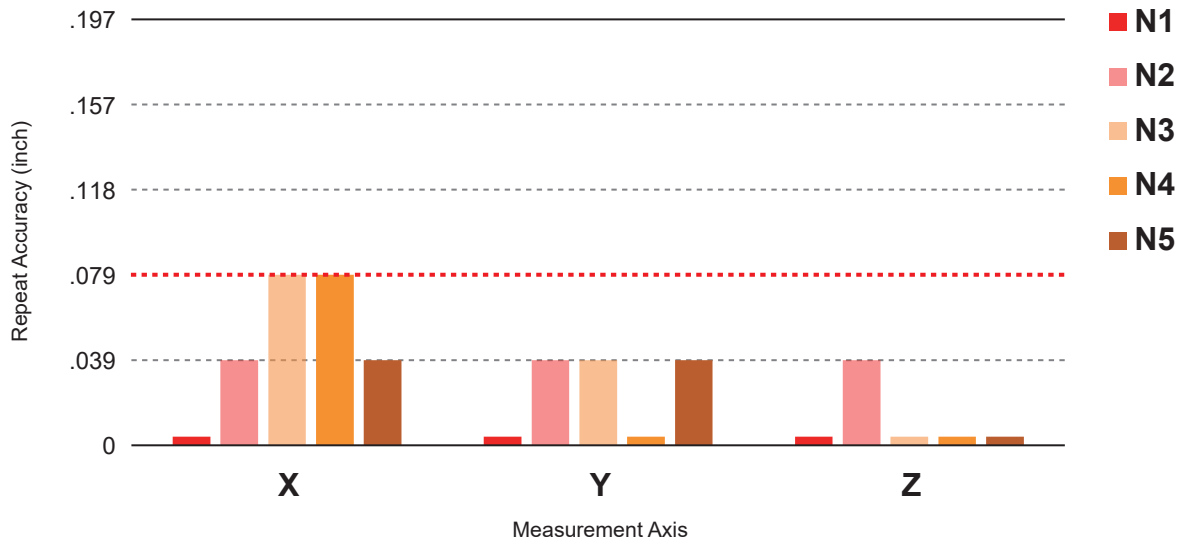

PSC Holder Order Number

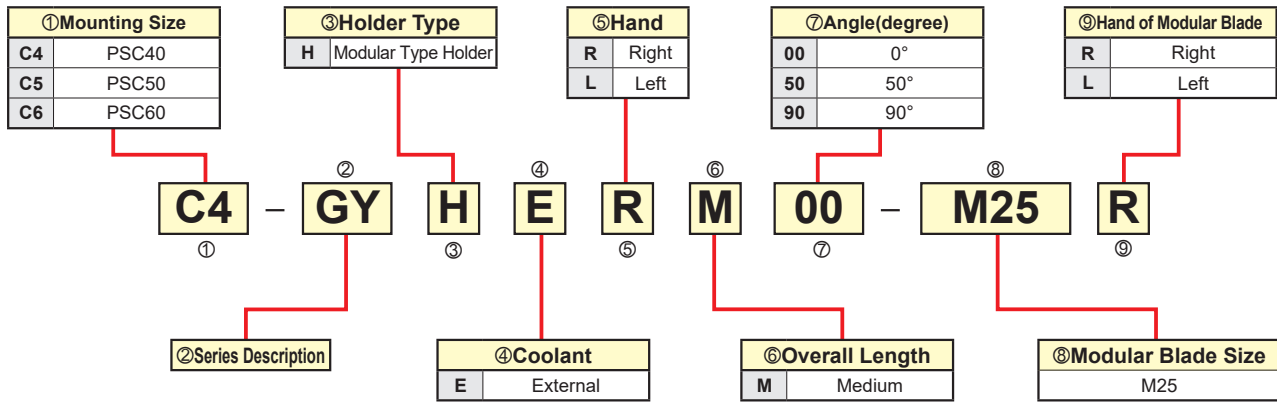

GY Series L Dimension Tolerance Conversion Table

The setting dimensions LF and LH shown on the next pages will change depending on the installed insert. The standard published dimensions assume GM breakers for a cutting edge angle of 00 °90°, and BM breakers for 50°.

Cutting Width CW (mm)	*1 Dimensions L (mm)	*2 Dimensional tolerance (mm) versus standard dimension (L) of each breaker							
		GU	GS/GM	MS/MM	R/L-GM	Flat Top	MF	BM	GL
2.00	20.70	0	0	0	.004	0	.014	.008	.014
2.24	*3 (20.7)						.014		
2.39	20.70	0	0			0	.014		
2.50	20.70	0	0	0	.005	0	.014	.008	.014
2.74	*3 (20.7)						.014		
3.00	20.70	0	0	0	.006	0	.014	.008	.014
3.18	20.70	0	0			0	.014	.008	
3.24	*3 (20.7)						.014		
4.00	25.65	0	0	0	.008	0	.012	.006	
4.24	*3 (25.65)						.012		
4.75	25.65	0	0			0	.012	.006	
5.00	25.65	0	0	0	.012	0	.012	.006	
5.24	*3 (25.65)						.012		
6.00	25.65	0	0	0		0	.012	.010	
6.31	*3 (25.65)						.012		
6.35	25.65	0	0				.012	.010	

*1 This value is used at the described holder dimension.
 *2 when there is no applicable breaker.
 *3 The standard dimensions shown here use an approximate insert width.

GY SERIES (EXTERNAL) NEW

PSC 00° type holder (Metric)

Note 1) Please order the modular blade and modular holder separately.

Note 2) Please set the right hand modular blade at the right hand holder and the left hand modular blade at the left hand holder.

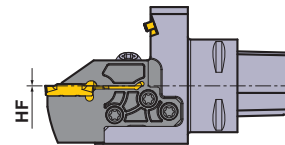
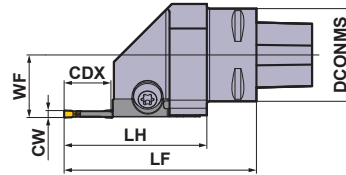

Right hand tool holder shown.

(mm)

Order Number	Stock	Hand (R/L)	Coolant	Mounting Size	DCONMS	CW
C4-GYHERM00-M25R	●	R	External	PSC40	40	2.0—6.35
C4-GYHELM00-M25L	●	L	External	PSC40	40	2.0—6.35
C5-GYHERM00-M25R	●	R	External	PSC50	50	2.0—6.35
C5-GYHELM00-M25L	●	L	External	PSC50	50	2.0—6.35
C6-GYHERM00-M25R	●	R	External	PSC60	60	2.0—6.35
C6-GYHELM00-M25L	●	L	External	PSC60	60	2.0—6.35

● = NEW

Set Dimensions with Modular Blades

Holder Type	Modular Blade Type	Standard CW	CDX	WF	HF	LF	LH
C4-GYHER/LM00-M25R/L	GYM25R/L○-D06	2.0	6	27.0	0	69	47.6
C4-GYHER/LM00-M25R/L	GYM25R/L○-D12	2.0	12	27.0	0	77	55.6
C4-GYHER/LM00-M25R/L	GYM25R/L○-D20	2.0	20	27.0	0	83	61.6
C4-GYHER/LM00-M25R/L	GYM25R/L○-E06	2.5	6	27.0	0	69	47.6
C4-GYHER/LM00-M25R/L	GYM25R/L○-E12	2.5	12	27.0	0	77	55.6
C4-GYHER/LM00-M25R/L	GYM25R/L○-E20	2.5	20	27.0	0	83	61.6
C4-GYHER/LM00-M25R/L	GYM25R/L○-F06	3.0	6	27.0	0	69	47.6
C4-GYHER/LM00-M25R/L	GYM25R/L○-F12	3.0	12	27.0	0	77	55.6
C4-GYHER/LM00-M25R/L	GYM25R/L○-F20	3.0	20	27.0	0	83	61.6
C4-GYHER/LM00-M25R/L	GYM25R/L○-G08	4.0	8	27.0	0	71	49.6
C4-GYHER/LM00-M25R/L	GYM25R/L○-G14	4.0	14	27.0	0	77	55.6
C4-GYHER/LM00-M25R/L	GYM25R/L○-G25	4.0	25	27.0	0	88	66.6
C4-GYHER/LM00-M25R/L	GYM25R/L○-H08	5.0	8	27.0	0	71	49.6
C4-GYHER/LM00-M25R/L	GYM25R/L○-H14	5.0	14	27.0	0	77	55.6
C4-GYHER/LM00-M25R/L	GYM25R/L○-H25	5.0	25	27.0	0	88	66.6
C4-GYHER/LM00-M25R/L	GYM25R/L○-J08	6.0	8	27.0	0	71	49.6
C4-GYHER/LM00-M25R/L	GYM25R/L○-J14	6.0	14	27.0	0	77	55.6
C4-GYHER/LM00-M25R/L	GYM25R/L○-J25	6.0	25	27.0	0	88	66.6

*Modular blade type: Blades for face machining indicate a code for the minimum face grooving diameter. Example) GYM25RD-D12-040

The "○" symbol is a position to insert the letter "A" for external diameter machining or "D" for face machining.

To select modular blades, refer to the Modular Blade List (starting from pg.11).

Note 1) The indicated dimensions are values for standard inserts (GM breakers). If other inserts are mounted, LF and LH may differ. Select the inserts and recommended conditions from "TOOL NEWS B255J-G GYGW Inserts". Links to PDF data are provided at the end of the document using QR codes.

● : USA Stock

(mm)

Holder Type	Modular Blade Type	Standard CW	CDX	WF	HF	LF	LH
C5-GYHER/LM00-M25R/L	GYM25R/L [○] -D06	2.0	6	35.0	0	69	47.6
C5-GYHER/LM00-M25R/L	GYM25R/L [○] -D12	2.0	12	35.0	0	77	55.6
C5-GYHER/LM00-M25R/L	GYM25R/L [○] -D20	2.0	20	35.0	0	83	61.6
C5-GYHER/LM00-M25R/L	GYM25R/L [○] -E06	2.5	6	35.0	0	69	47.6
C5-GYHER/LM00-M25R/L	GYM25R/L [○] -E12	2.5	12	35.0	0	77	55.6
C5-GYHER/LM00-M25R/L	GYM25R/L [○] -E20	2.5	20	35.0	0	83	61.6
C5-GYHER/LM00-M25R/L	GYM25R/L [○] -F06	3.0	6	35.0	0	69	47.6
C5-GYHER/LM00-M25R/L	GYM25R/L [○] -F12	3.0	12	35.0	0	77	55.6
C5-GYHER/LM00-M25R/L	GYM25R/L [○] -F20	3.0	20	35.0	0	83	61.6
C5-GYHER/LM00-M25R/L	GYM25R/L [○] -G08	4.0	8	35.0	0	71	49.6
C5-GYHER/LM00-M25R/L	GYM25R/L [○] -G14	4.0	14	35.0	0	77	55.6
C5-GYHER/LM00-M25R/L	GYM25R/L [○] -G25	4.0	25	35.0	0	88	66.6
C5-GYHER/LM00-M25R/L	GYM25R/L [○] -H08	5.0	8	35.0	0	71	49.6
C5-GYHER/LM00-M25R/L	GYM25R/L [○] -H14	5.0	14	35.0	0	77	55.6
C5-GYHER/LM00-M25R/L	GYM25R/L [○] -H25	5.0	25	35.0	0	88	66.6
C5-GYHER/LM00-M25R/L	GYM25R/L [○] -J08	6.0	8	35.0	0	71	49.6
C5-GYHER/LM00-M25R/L	GYM25R/L [○] -J14	6.0	14	35.0	0	77	55.6
C5-GYHER/LM00-M25R/L	GYM25R/L [○] -J25	6.0	25	35.0	0	88	66.6
C6-GYHER/LM00-M25R/L	GYM25R/L [○] -D06	2.0	6	45.0	0	71	47.6
C6-GYHER/LM00-M25R/L	GYM25R/L [○] -D12	2.0	12	45.0	0	79	55.6
C6-GYHER/LM00-M25R/L	GYM25R/L [○] -D20	2.0	20	45.0	0	85	61.6
C6-GYHER/LM00-M25R/L	GYM25R/L [○] -E06	2.5	6	45.0	0	71	47.6
C6-GYHER/LM00-M25R/L	GYM25R/L [○] -E12	2.5	12	45.0	0	79	55.6
C6-GYHER/LM00-M25R/L	GYM25R/L [○] -E20	2.5	20	45.0	0	85	61.6
C6-GYHER/LM00-M25R/L	GYM25R/L [○] -F06	3.0	6	45.0	0	71	47.6
C6-GYHER/LM00-M25R/L	GYM25R/L [○] -F12	3.0	12	45.0	0	79	55.6
C6-GYHER/LM00-M25R/L	GYM25R/L [○] -F20	3.0	20	45.0	0	85	61.6
C6-GYHER/LM00-M25R/L	GYM25R/L [○] -G08	4.0	8	45.0	0	73	49.6
C6-GYHER/LM00-M25R/L	GYM25R/L [○] -G14	4.0	14	45.0	0	79	55.6
C6-GYHER/LM00-M25R/L	GYM25R/L [○] -G25	4.0	25	45.0	0	90	66.6
C6-GYHER/LM00-M25R/L	GYM25R/L [○] -H08	5.0	8	45.0	0	73	49.6
C6-GYHER/LM00-M25R/L	GYM25R/L [○] -H14	5.0	14	45.0	0	79	55.6
C6-GYHER/LM00-M25R/L	GYM25R/L [○] -H25	5.0	25	45.0	0	90	66.6
C6-GYHER/LM00-M25R/L	GYM25R/L [○] -J08	6.0	8	45.0	0	73	49.6
C6-GYHER/LM00-M25R/L	GYM25R/L [○] -J14	6.0	14	45.0	0	79	55.6
C6-GYHER/LM00-M25R/L	GYM25R/L [○] -J25	6.0	25	45.0	0	90	66.6







*Modular blade type: Blades for face machining indicate a code for the minimum face grooving diameter. Example) GYM25RD-D12-040

The "○" symbol is a position to insert the letter "A" for external diameter machining or "D" for face machining.

To select modular blades, refer to the Modular Blade List (starting from pg.11).

Note 1) The indicated dimensions are values for standard inserts (GM breakers). If other inserts are mounted, LF and LH may differ. Select the inserts and recommended conditions from "TOOL NEWS B255J-G GYGW Inserts". Links to PDF data are provided at the end of the document using QR codes.

Spare Parts

 *		 *									
Order Number	Pcs.	Order Number	Pcs.	Order Number	Pcs.	Order Number	Pcs.	Order Number	Order Number		
GY06013M	1	TS55	5	HSD05004S	1	NZ22042080S	1	TKY25D	TKY30R		

* Clamp Torque (lbf-in) : GY06013M=53, TS55=44

Nozzle Exchange Key : NZKH050S

GY SERIES (EXTERNAL) NEW

PSC 90° type holder (Metric)

Note 1) Please order the modular blade and modular holder separately.

Note 2) Please set the left hand modular blade at the right hand holder and the right hand modular blade at the left hand holder.

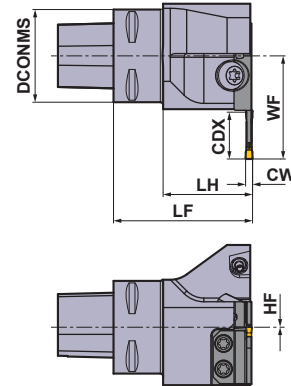
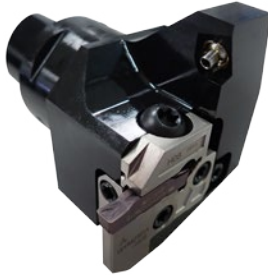

Left hand tool holder shown.

(mm)

Order Number	Stock	Hand (R/L)	Coolant	Mounting Size	DCONMS	CW
C4-GYHERM90-M25L	●	R	External	PSC40	40	2.0—6.35
C4-GYHELM90-M25R	●	L	External	PSC40	40	2.0—6.35
C5-GYHERM90-M25L	●	R	External	PSC50	50	2.0—6.35
C5-GYHELM90-M25R	●	L	External	PSC50	50	2.0—6.35
C6-GYHERM90-M25L	●	R	External	PSC60	60	2.0—6.35
C6-GYHELM90-M25R	●	L	External	PSC60	60	2.0—6.35

● = NEW

Set Dimensions with Modular Blades

Holder Type	Modular Blade Type	Standard CW	CDX	WF	HF	LF	LH
C4-GYHER/LM90-M25L/R	GYM25L/R○D06	2.0	6	30.5	0	60	38.6
C4-GYHER/LM90-M25L/R	GYM25L/R○D12	2.0	12	38.5	0	60	38.6
C4-GYHER/LM90-M25L/R	GYM25L/R○D20	2.0	20	44.5	0	60	38.6
C4-GYHER/LM90-M25L/R	GYM25L/R○E06	2.5	6	30.5	0	60	38.6
C4-GYHER/LM90-M25L/R	GYM25L/R○E12	2.5	12	38.5	0	60	38.6
C4-GYHER/LM90-M25L/R	GYM25L/R○E20	2.5	20	44.5	0	60	38.6
C4-GYHER/LM90-M25L/R	GYM25L/R○F06	3.0	6	30.5	0	60	38.6
C4-GYHER/LM90-M25L/R	GYM25L/R○F12	3.0	12	38.5	0	60	38.6
C4-GYHER/LM90-M25L/R	GYM25L/R○F20	3.0	20	44.5	0	60	38.6
C4-GYHER/LM90-M25L/R	GYM25L/R○G08	4.0	8	32.5	0	60	38.6
C4-GYHER/LM90-M25L/R	GYM25L/R○G14	4.0	14	38.5	0	60	38.6
C4-GYHER/LM90-M25L/R	GYM25L/R○G25	4.0	25	49.5	0	60	38.6
C4-GYHER/LM90-M25L/R	GYM25L/R○H08	5.0	8	32.5	0	60	38.6
C4-GYHER/LM90-M25L/R	GYM25L/R○H14	5.0	14	38.5	0	60	38.6
C4-GYHER/LM90-M25L/R	GYM25L/R○H25	5.0	25	49.5	0	60	38.6
C4-GYHER/LM90-M25L/R	GYM25L/R○J08	6.0	8	32.5	0	60	38.6
C4-GYHER/LM90-M25L/R	GYM25L/R○J14	6.0	14	38.5	0	60	38.6
C4-GYHER/LM90-M25L/R	GYM25L/R○J25	6.0	25	49.5	0	60	38.6

*Modular blade type: Blades for face machining indicate a code for the minimum face grooving diameter. Example) GYM25RD-D12-040

The "○" symbol is a position to insert the letter "A" for external diameter machining or "D" for face machining.

To select modular blades, refer to the Modular Blade List (starting from pg.11).

Note 1) The indicated dimensions are values for standard inserts (GM breakers). If other inserts are mounted, LF and LH may differ. Select the inserts and recommended conditions from "TOOL NEWS B255J-G GYGW Inserts". Links to PDF data are provided at the end of the document using QR codes.

● : USA Stock

(mm)

Holder Type	Modular Blade Type	Standard CW	CDX	WF	HF	LF	LH
C5-GYHER/LM90-M25L/R	GYM25L/R-D06	2.0	6	33.0	0	60	38.6
C5-GYHER/LM90-M25L/R	GYM25L/R-D12	2.0	12	41.0	0	60	38.6
C5-GYHER/LM90-M25L/R	GYM25L/R-D20	2.0	20	47.0	0	60	38.6
C5-GYHER/LM90-M25L/R	GYM25L/R-E06	2.5	6	33.0	0	60	38.6
C5-GYHER/LM90-M25L/R	GYM25L/R-E12	2.5	12	41.0	0	60	38.6
C5-GYHER/LM90-M25L/R	GYM25L/R-E20	2.5	20	47.0	0	60	38.6
C5-GYHER/LM90-M25L/R	GYM25L/R-F06	3.0	6	33.0	0	60	38.6
C5-GYHER/LM90-M25L/R	GYM25L/R-F12	3.0	12	41.0	0	60	38.6
C5-GYHER/LM90-M25L/R	GYM25L/R-F20	3.0	20	47.0	0	60	38.6
C5-GYHER/LM90-M25L/R	GYM25L/R-G08	4.0	8	35.0	0	60	38.6
C5-GYHER/LM90-M25L/R	GYM25L/R-G14	4.0	14	41.0	0	60	38.6
C5-GYHER/LM90-M25L/R	GYM25L/R-G25	4.0	25	52.0	0	60	38.6
C5-GYHER/LM90-M25L/R	GYM25L/R-H08	5.0	8	35.0	0	60	38.6
C5-GYHER/LM90-M25L/R	GYM25L/R-H14	5.0	14	41.0	0	60	38.6
C5-GYHER/LM90-M25L/R	GYM25L/R-H25	5.0	25	52.0	0	60	38.6
C5-GYHER/LM90-M25L/R	GYM25L/R-J08	6.0	8	35.0	0	60	38.6
C5-GYHER/LM90-M25L/R	GYM25L/R-J14	6.0	14	41.0	0	60	38.6
C5-GYHER/LM90-M25L/R	GYM25L/R-J25	6.0	25	52.0	0	60	38.6
C6-GYHER/LM90-M25L/R	GYM25L/R-D06	2.0	6	40.0	0	70	46.6
C6-GYHER/LM90-M25L/R	GYM25L/R-D12	2.0	12	48.0	0	70	46.6
C6-GYHER/LM90-M25L/R	GYM25L/R-D20	2.0	20	54.0	0	70	46.6
C6-GYHER/LM90-M25L/R	GYM25L/R-E06	2.5	6	40.0	0	70	46.6
C6-GYHER/LM90-M25L/R	GYM25L/R-E12	2.5	12	48.0	0	70	46.6
C6-GYHER/LM90-M25L/R	GYM25L/R-E20	2.5	20	54.0	0	70	46.6
C6-GYHER/LM90-M25L/R	GYM25L/R-F06	3.0	6	40.0	0	70	46.6
C6-GYHER/LM90-M25L/R	GYM25L/R-F12	3.0	12	48.0	0	70	46.6
C6-GYHER/LM90-M25L/R	GYM25L/R-F20	3.0	20	54.0	0	70	46.6
C6-GYHER/LM90-M25L/R	GYM25L/R-G08	4.0	8	42.0	0	70	46.6
C6-GYHER/LM90-M25L/R	GYM25L/R-G14	4.0	14	48.0	0	70	46.6
C6-GYHER/LM90-M25L/R	GYM25L/R-G25	4.0	25	59.0	0	70	46.6
C6-GYHER/LM90-M25L/R	GYM25L/R-H08	5.0	8	42.0	0	70	46.6
C6-GYHER/LM90-M25L/R	GYM25L/R-H14	5.0	14	48.0	0	70	46.6
C6-GYHER/LM90-M25L/R	GYM25L/R-H25	5.0	25	59.0	0	70	46.6
C6-GYHER/LM90-M25L/R	GYM25L/R-J08	6.0	8	42.0	0	70	46.6
C6-GYHER/LM90-M25L/R	GYM25L/R-J14	6.0	14	48.0	0	70	46.6
C6-GYHER/LM90-M25L/R	GYM25L/R-J25	6.0	25	59.0	0	70	46.6







*Modular blade type: Blades for face machining indicate a code for the minimum face grooving diameter. Example) GYM25RD-D12-040

The "○" symbol is a position to insert the letter "A" for external diameter machining or "D" for face machining.

To select modular blades, refer to the Modular Blade List (starting from pg.11).

Note 1) The indicated dimensions are values for standard inserts (GM breakers). If other inserts are mounted, LF and LH may differ. Select the inserts and recommended conditions from "TOOL NEWS B255J-G GYGW Inserts". Links to PDF data are provided at the end of the document using QR codes.

Spare Parts

 *		 *									
Order Number	Pcs.	Order Number	Pcs.	Order Number	Pcs.	Order Number	Pcs.	Order Number	Order Number		
GY06013M	1	TS55	5	HSD05004S	1	NZ22042080S	1	TKY25D	TKY30R		

* Clamp Torque (lbf-in) : GY06013M=53, TS55=44

Nozzle Exchange Key : NZKH050S

GY SERIES (FOR RECESSING) NEW

PSC 50° type holder (Metric)

Note 1) Please order the modular blade and modular holder separately.
 Note 2) Please set the left hand modular blade at the right hand holder and the right hand modular blade at the left hand holder.

- P
M
K
N
S
H

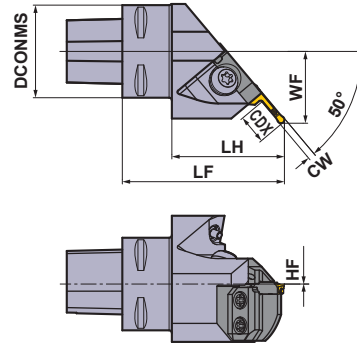

Left hand tool holder shown.

(mm)

Order Number	Stock	Hand (R/L)	Coolant	Mounting Size	DCONMS	CW
C4-GYHERM50-M25L	●	R	External	PSC40	40	2.0-6.35
C4-GYHELM50-M25R	●	L	External	PSC40	40	2.0-6.35
C5-GYHERM50-M25L	●	R	External	PSC50	50	2.0-6.35
C5-GYHELM50-M25R	●	L	External	PSC50	50	2.0-6.35
C6-GYHERM50-M25L	●	R	External	PSC60	60	2.0-6.35
C6-GYHELM50-M25R	●	L	External	PSC60	60	2.0-6.35

● = NEW

Spare Parts

*		*									
Order Number	Pcs.	Order Number	Pcs.	Order Number	Pcs.	Order Number	Pcs.	Order Number	Order Number	Order Number	Order Number
GY06013M	1	TS55	4	HSD05004S	1	NZ22042080S	1	TKY25D	TKY30R		

* Clamp Torque (lbf-in) : GY06013M=53, TS55=44
 Nozzle Exchange Key : NZKH050S

● : USA Stock

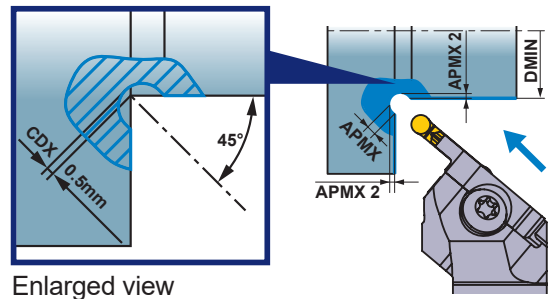

Enlarged view

Set Dimensions with Modular Blades

(mm)

Holder Type	Modular Blade Type	Standard CW	CDX	DMIN	APMX	APMX2	WF	HF	LF	LH
C4-GYHER/LM50-M25L/R	GYM25L/RC-D005	2.0	0.5	30	1.50	0.646	30.6	0	70.2	48.8
C4-GYHER/LM50-M25L/R	GYM25L/RC-E005	2.5	0.5	30	1.75	0.720	30.8	0	70.1	48.7
C4-GYHER/LM50-M25L/R	GYM25L/RC-F005	3.0	0.5	30	2.00	0.793	31.0	0	70.0	48.6
C4-GYHER/LM50-M25L/R	GYM25L/RC-G005	4.0	0.5	20	2.50	0.939	31.4	0	69.8	48.4
C4-GYHER/LM50-M25L/R	GYM25L/RC-H005	5.0	0.5	20	2.88	1.049	31.8	0	69.6	48.2
C4-GYHER/LM50-M25L/R	GYM25L/RC-J005	6.0	0.5	20	3.50	1.232	32.4	0	69.4	48.0
C5-GYHER/LM50-M25L/R	GYM25L/RC-D005	2.0	0.5	30	1.50	0.646	32.6	0	70.2	48.8
C5-GYHER/LM50-M25L/R	GYM25L/RC-E005	2.5	0.5	30	1.75	0.720	32.8	0	70.1	48.7
C5-GYHER/LM50-M25L/R	GYM25L/RC-F005	3.0	0.5	30	2.00	0.793	33.0	0	70.0	48.6
C5-GYHER/LM50-M25L/R	GYM25L/RC-G005	4.0	0.5	20	2.50	0.939	33.4	0	69.8	48.4
C5-GYHER/LM50-M25L/R	GYM25L/RC-H005	5.0	0.5	20	2.88	1.049	33.8	0	69.6	48.2
C5-GYHER/LM50-M25L/R	GYM25L/RC-J005	6.0	0.5	20	3.50	1.232	34.4	0	69.4	48.0
C6-GYHER/LM50-M25L/R	GYM25L/RC-D005	2.0	0.5	30	1.50	0.646	39.6	0	70.2	46.8
C6-GYHER/LM50-M25L/R	GYM25L/RC-E005	2.5	0.5	30	1.75	0.720	39.8	0	70.1	46.7
C6-GYHER/LM50-M25L/R	GYM25L/RC-F005	3.0	0.5	30	2.00	0.793	40.0	0	70.0	46.6
C6-GYHER/LM50-M25L/R	GYM25L/RC-G005	4.0	0.5	20	2.50	0.939	40.4	0	69.8	46.4
C6-GYHER/LM50-M25L/R	GYM25L/RC-H005	5.0	0.5	20	2.88	1.049	40.8	0	69.6	46.2
C6-GYHER/LM50-M25L/R	GYM25L/RC-J005	6.0	0.5	20	3.50	1.232	41.4	0	69.4	46.0

DMIN = Min. Cut Diameter

*Modular blade type: Blades for face machining indicate a code for the minimum face grooving diameter. Example) GYM25RD-D12-040

The "○" symbol is a position to insert the letter "A" for external diameter machining or "D" for face machining.

To select modular blades, refer to the Modular Blade List (starting from pg.11).

Note 1) The indicated dimensions are values for standard inserts (GM breakers). If other inserts are mounted, LF and LH may differ. Select the inserts and recommended conditions from "TOOL NEWS B255J-G GYGW Inserts". Links to PDF data are provided at the end of the document using QR codes.

Modular Blade Order Number

■ MODULAR BLADE

● EXTERNAL/FOR RECESSING

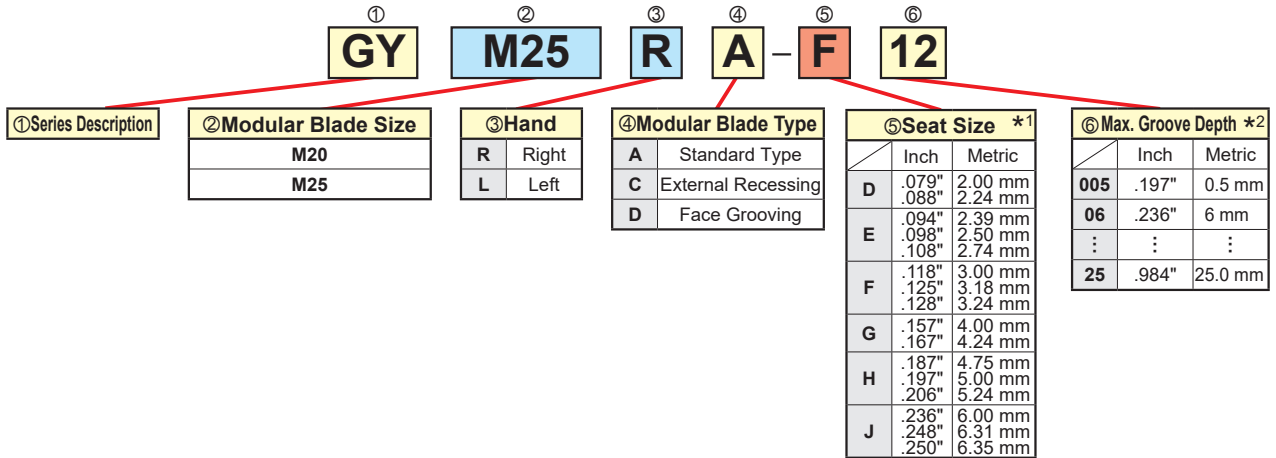

● FACE GROOVING

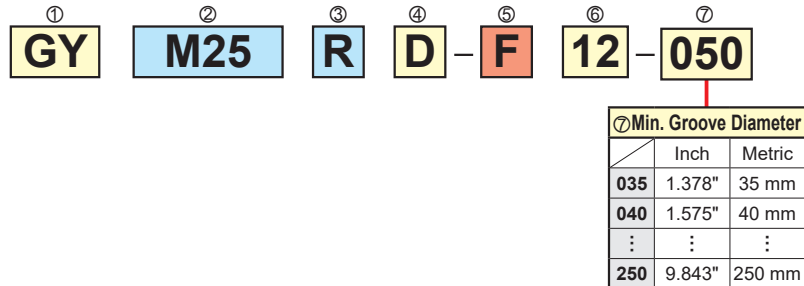

*1 Select a seat size with the same symbol as that of the insert.

*2 The maximum groove depth is a value when used for external grooving and changes according to the insert used.

Modular Blades Selection Chart

Holder Angle	Cutting Mode	Holder Type	Hand (R/L)	Seat Size	Modular Blade		Holder Angle	Cutting Mode	Holder Type	Hand (R/L)	Seat Size	Modular Blade	
					Order Number	Hand (R/L)						Order Number	Hand (R/L)
00°	External	C-GYHERM00-M25R	R	D	GYM25RA-D06	R	00°	Face Grooving	C-GYHERM00-M25R	R	G	GYM25RD-G14-085	R
				D	GYM25RA-D12	R					G	GYM25RD-G14-125	R
				D	GYM25RA-D20	R					G	GYM25RD-G14-180	R
				E	GYM25RA-E06	R					G	GYM25RD-G14-250	R
				E	GYM25RA-E12	R					G	GYM25RD-G25-060	R
				E	GYM25RA-E20	R					G	GYM25RD-G25-085	R
				F	GYM25RA-F06	R					G	GYM25RD-G25-125	R
				F	GYM25RA-F12	R					G	GYM25RD-G25-180	R
				F	GYM25RA-F20	R					G	GYM25RD-G25-250	R
				G	GYM25RA-G08	R					H	GYM25RD-H14-050	R
				G	GYM25RA-G14	R					H	GYM25RD-H14-060	R
				G	GYM25RA-G25	R					H	GYM25RD-H14-085	R
				H	GYM25RA-H08	R					H	GYM25RD-H14-125	R
				H	GYM25RA-H14	R					H	GYM25RD-H14-180	R
				H	GYM25RA-H25	R					H	GYM25RD-H14-250	R
				J	GYM25RA-J08	R					H	GYM25RD-H25-060	R
				J	GYM25RA-J14	R					H	GYM25RD-H25-085	R
				J	GYM25RA-J25	R					H	GYM25RD-H25-125	R
		C-GYHELM00-M25L	L	D	GYM25LA-D06	L					H	GYM25RD-H25-180	R
				D	GYM25LA-D12	L					H	GYM25RD-H25-250	R
				D	GYM25LA-D20	L					J	GYM25RD-J14-050	R
				E	GYM25LA-E06	L					J	GYM25RD-J14-070	R
				E	GYM25LA-E12	L					J	GYM25RD-J14-110	R
				E	GYM25LA-E20	L					J	GYM25RD-J14-170	R
				F	GYM25LA-F06	L					J	GYM25RD-J14-250	R
				F	GYM25LA-F12	L					J	GYM25RD-J25-070	R
				F	GYM25LA-F20	L					J	GYM25RD-J25-110	R
				G	GYM25LA-G08	L					J	GYM25RD-J25-170	R
				G	GYM25LA-G14	L					J	GYM25RD-J25-250	R
				G	GYM25LA-G25	L					D	GYM25LD-D12-040	L
				H	GYM25LA-H08	L					D	GYM25LD-D12-050	L
				H	GYM25LA-H14	L					D	GYM25LD-D12-060	L
				H	GYM25LA-H25	L					D	GYM25LD-D12-075	L
				J	GYM25LA-J08	L					D	GYM25LD-D12-075	L
				J	GYM25LA-J14	L					D	GYM25LD-D12-100	L
				J	GYM25LA-J25	L					D	GYM25LD-D12-100	L
C-GYHERM00-M25R	R	D	GYM25RD-D12-040	R	D	GYM25LD-D12-135	L						
		D	GYM25RD-D12-050	R	D	GYM25LD-D12-180	L						
		D	GYM25RD-D12-060	R	E	GYM25LD-E12-040	L						
		D	GYM25RD-D12-075	R	E	GYM25LD-E12-050	L						
		D	GYM25RD-D12-100	R	E	GYM25LD-E12-060	L						
		D	GYM25RD-D12-135	R	E	GYM25LD-E12-075	L						
		D	GYM25RD-D12-180	R	E	GYM25LD-E12-100	L						
		E	GYM25RD-E12-040	R	E	GYM25LD-E12-135	L						
		E	GYM25RD-E12-050	R	E	GYM25LD-E12-180	L						
		E	GYM25RD-E12-060	R	F	GYM25LD-F12-035	L						
		E	GYM25RD-E12-075	R	F	GYM25LD-F12-040	L						
		E	GYM25RD-E12-100	R	F	GYM25LD-F12-050	L						
		E	GYM25RD-E12-135	R	F	GYM25LD-F12-060	L						
		E	GYM25RD-E12-180	R	F	GYM25LD-F12-075	L						
		F	GYM25RD-F12-035	R	F	GYM25LD-F12-100	L						
		F	GYM25RD-F12-040	R	F	GYM25LD-F12-135	L						
		F	GYM25RD-F12-050	R	F	GYM25LD-F12-180	L						
		F	GYM25RD-F12-060	R	F	GYM25LD-F12-225	L						
		F	GYM25RD-F12-075	R	F	GYM25LD-F20-060	L						
		F	GYM25RD-F12-100	R	F	GYM25LD-F20-075	L						
		F	GYM25RD-F12-135	R	F	GYM25LD-F20-100	L						
		F	GYM25RD-F12-180	R	F	GYM25LD-F20-135	L						
		F	GYM25RD-F12-225	R	F	GYM25LD-F20-180	L						
		F	GYM25RD-F20-060	R	F	GYM25LD-F20-225	L						
		F	GYM25RD-F20-075	R	G	GYM25LD-G14-040	L						
		F	GYM25RD-F20-100	R	G	GYM25LD-G14-050	L						
		F	GYM25RD-F20-135	R	G	GYM25LD-G14-060	L						
		F	GYM25RD-F20-180	R	G	GYM25LD-G14-085	L						
		F	GYM25RD-F20-225	R	G	GYM25LD-G14-125	L						
		G	GYM25RD-G14-040	R	G	GYM25LD-G14-180	L						
		G	GYM25RD-G14-050	R	G	GYM25LD-G14-250	L						
		G	GYM25RD-G14-060	R	G	GYM25LD-G25-060	L						
					G	GYM25LD-G25-085	L						
					G	GYM25LD-G25-125	L						

Grooving System

Modular Blades Selection Chart

Holder Angle	Cutting Mode	Holder Type	Hand (R/L)	Seat Size	Modular Blade		Holder Angle	Cutting Mode	Holder Type	Hand (R/L)	Seat Size	Modular Blade								
					Order Number	Hand (R/L)						Order Number	Hand (R/L)							
00°	Face Grooving	GYHELM00-M25L	L	G	GYM25LD-G25-180	L	90°	Face Grooving	GYHERM90-M25L	R	E	GYM25LD-E12-075	L							
				G	GYM25LD-G25-250	L					E	GYM25LD-E12-100	L							
				H	GYM25LD-H14-050	L					E	GYM25LD-E12-135	L							
				H	GYM25LD-H14-060	L					E	GYM25LD-E12-180	L							
				H	GYM25LD-H14-085	L					F	GYM25LD-F12-035	L							
				H	GYM25LD-H14-125	L					F	GYM25LD-F12-040	L							
				H	GYM25LD-H14-180	L					F	GYM25LD-F12-050	L							
				H	GYM25LD-H14-250	L					F	GYM25LD-F12-060	L							
				H	GYM25LD-H25-060	L					F	GYM25LD-F12-075	L							
				H	GYM25LD-H25-085	L					F	GYM25LD-F12-100	L							
				H	GYM25LD-H25-125	L					F	GYM25LD-F12-135	L							
				H	GYM25LD-H25-180	L					F	GYM25LD-F12-180	L							
				H	GYM25LD-H25-250	L					F	GYM25LD-F12-225	L							
				J	GYM25LD-J14-050	L					F	GYM25LD-F20-060	L							
				J	GYM25LD-J14-070	L					F	GYM25LD-F20-075	L							
				J	GYM25LD-J14-110	L					F	GYM25LD-F20-100	L							
				J	GYM25LD-J14-170	L					F	GYM25LD-F20-135	L							
				J	GYM25LD-J14-250	L					F	GYM25LD-F20-180	L							
				J	GYM25LD-J25-070	L					F	GYM25LD-F20-225	L							
				90°	External	GYHERM90-M25L					R	D	GYM25LA-D06	L	90°	Face Grooving	GYHELM90-M25R	L	G	GYM25LD-G14-040
D	GYM25LA-D12	L	G				GYM25LD-G14-050	L												
D	GYM25LA-D20	L	G				GYM25LD-G14-060	L												
E	GYM25LA-E06	L	G				GYM25LD-G14-085	L												
E	GYM25LA-E12	L	G				GYM25LD-G14-125	L												
E	GYM25LA-E20	L	G				GYM25LD-G14-180	L												
F	GYM25LA-F06	L	G				GYM25LD-G14-250	L												
F	GYM25LA-F12	L	G				GYM25LD-G25-060	L												
F	GYM25LA-F20	L	G				GYM25LD-G25-085	L												
G	GYM25LA-G08	L	G				GYM25LD-G25-125	L												
G	GYM25LA-G14	L	G			GYM25LD-G25-180	L													
G	GYM25LA-G25	L	G			GYM25LD-G25-250	L													
H	GYM25LA-H08	L	H			GYM25LD-H14-050	L													
H	GYM25LA-H14	L	H			GYM25LD-H14-060	L													
H	GYM25LA-H25	L	H			GYM25LD-H14-085	L													
J	GYM25LA-J08	L	H			GYM25LD-H14-125	L													
J	GYM25LA-J14	L	H			GYM25LD-H14-180	L													
J	GYM25LA-J25	L	H			GYM25LD-H14-250	L													
90°	Face Grooving	GYHELM90-M25R	L			D	GYM25RA-D06	R	90°	Face Grooving		GYHELM90-M25R	L	H					GYM25LD-H25-060	L
						D	GYM25RA-D12	R						H					GYM25LD-H25-085	L
				D	GYM25RA-D20	R	H	GYM25LD-H25-125			L									
				E	GYM25RA-E06	R	H	GYM25LD-H25-180			L									
				E	GYM25RA-E12	R	H	GYM25LD-H25-250			L									
				E	GYM25RA-E20	R	J	GYM25LD-J14-050			L									
				F	GYM25RA-F06	R	J	GYM25LD-J14-070			L									
				F	GYM25RA-F12	R	J	GYM25LD-J14-110			L									
				F	GYM25RA-F20	R	J	GYM25LD-J14-170			L									
				G	GYM25RA-G08	R	J	GYM25LD-J14-250			L									
		G		GYM25RA-G14	R	J	GYM25LD-J25-070	L												
		G		GYM25RA-G25	R	J	GYM25LD-J25-110	L												
		H		GYM25RA-H08	R	J	GYM25LD-J25-170	L												
		H		GYM25RA-H14	R	D	GYM25RD-D12-040	R												
		H		GYM25RA-H25	R	D	GYM25RD-D12-050	R												
		J		GYM25RA-J08	R	D	GYM25RD-D12-060	R												
		J		GYM25RA-J14	R	D	GYM25RD-D12-075	R												
		J		GYM25RA-J25	R	D	GYM25RD-D12-100	R												
		90°		Face Grooving	GYHERM90-M25L	R	D	GYM25LD-D12-040			L			90°	Face Grooving	GYHELM90-M25R	L	D	GYM25RD-D12-135	R
							D	GYM25LD-D12-050			L							D	GYM25RD-D12-180	R
D	GYM25LD-D12-060		L				E	GYM25RD-E12-040	R											
D	GYM25LD-D12-075		L				E	GYM25RD-E12-050	R											
D	GYM25LD-D12-100		L				E	GYM25RD-E12-060	R											
D	GYM25LD-D12-135		L				E	GYM25RD-E12-075	R											
D	GYM25LD-D12-180		L				E	GYM25RD-E12-100	R											
E	GYM25LD-E12-040		L				E	GYM25RD-E12-135	R											
E	GYM25LD-E12-050		L				E	GYM25RD-E12-180	R											
E	GYM25LD-E12-060		L				F	GYM25RD-F12-035	R											
						F	GYM25RD-F12-040	R												
						F	GYM25RD-F12-050	R												

Holder Angle	Cutting Mode	Holder Type	Hand (R/L)	Seat Size	Modular Blade	
					Order Number	Hand (R/L)
90°	Face Grooving	GYHELM90-M25R	L	F	GYM25RD-F12-060	R
				F	GYM25RD-F12-075	R
				F	GYM25RD-F12-100	R
				F	GYM25RD-F12-135	R
				F	GYM25RD-F12-180	R
				F	GYM25RD-F12-225	R
				F	GYM25RD-F20-060	R
				F	GYM25RD-F20-075	R
				F	GYM25RD-F20-100	R
				F	GYM25RD-F20-135	R
				F	GYM25RD-F20-180	R
				F	GYM25RD-F20-225	R
				G	GYM25RD-G14-040	R
				G	GYM25RD-G14-050	R
				G	GYM25RD-G14-060	R
				G	GYM25RD-G14-085	R
				G	GYM25RD-G14-125	R
				G	GYM25RD-G14-180	R
				G	GYM25RD-G14-250	R
				G	GYM25RD-G25-060	R
				G	GYM25RD-G25-085	R
				G	GYM25RD-G25-125	R
				G	GYM25RD-G25-180	R
				G	GYM25RD-G25-250	R
				H	GYM25RD-H14-050	R
				H	GYM25RD-H14-060	R
				H	GYM25RD-H14-085	R
				H	GYM25RD-H14-125	R
				H	GYM25RD-H14-180	R
				H	GYM25RD-H14-250	R
				H	GYM25RD-H25-060	R
				H	GYM25RD-H25-085	R
				H	GYM25RD-H25-125	R
				H	GYM25RD-H25-180	R
				H	GYM25RD-H25-250	R
				J	GYM25RD-J14-050	R
				J	GYM25RD-J14-070	R
				J	GYM25RD-J14-110	R
				J	GYM25RD-J14-170	R
				J	GYM25RD-J14-250	R
				J	GYM25RD-J25-070	R
				J	GYM25RD-J25-110	R
				J	GYM25RD-J25-170	R
				J	GYM25RD-J25-250	R

Holder Angle	Cutting Mode	Holder Type	Hand (R/L)	Seat Size	Modular Blade	
					Order Number	Hand (R/L)
50°	For Recessing	GYHERM50-M25L	R	D	GYM25LC-D005	L
				E	GYM25LC-E005	L
				F	GYM25LC-F005	L
				G	GYM25LC-G005	L
				H	GYM25LC-H005	L
				J	GYM25LC-J005	L
		GYHELM50-M25R	L	D	GYM25RC-D005	R
				E	GYM25RC-E005	R
				F	GYM25RC-F005	R
				G	GYM25RC-G005	R
				H	GYM25RC-H005	R
				J	GYM25RC-J005	R

Cutting Off & Grooving System

Please use the catalogues below for insert selection and recommended cutting conditions.

C009A 2019-2020

General Catalog



B255A-G TOOL NEWS

GY/GW Series Inserts



For your safety

●Don't touch breakers and chips without gloves. ●Please machine within recommended application range, and exchange expired tools with new parts in advance. ●Please use safety cover and wear safety glasses. ●When using compounded cutting oils, please take fire prevention. ●When attaching inserts or spare parts, please use the attached wrench or driver. ●When using tools in revolution machining, please make a trial run to check run-out, vibration, abnormal sounds etc.

MITSUBISHI MATERIALS U.S.A. CORPORATION

Customer Service : 800-523-0800
Technical Service : 800-486-2341

LOS ANGELES HEAD OFFICE
3535 Hyland Avenue, Suite 200, Costa Mesa, CA 92626
TEL : 714-352-6100 FAX : 714-668-1320

NORTH CAROLINA OFFICE
105 Corporate Center Drive Suite A, Mooresville, NC 28117
TEL : 980-312-3100 FAX : 704-746-9292

CHICAGO OFFICE
1314B North Plum Grove Road, Schaumburg, IL 60173
TEL : 847-252-6300 FAX : 847-519-1732

TORONTO OFFICE
3535 Laird Road, Units 15 & 16, Mississauga, Ontario, L5L 5Y7, Canada
TEL : 905-814-0240 FAX : 905-814-0245

MMC METAL DE MEXICO, S.A. DE C.V.
Av. La Cañada No.16, Parque Industrial Bernardo Quintana,
El Marques, Queretaro, CP76246, Mexico
TEL : +52-442-221-6136 FAX : +52-442-221-6134

URL : <http://www.mmus-carbide.com/>
(Tool specifications subject to change without notice.)

EXP-20-E013
Printed in U.S.A 4/21