



Adjustable micro boring unit Hi-Bore fine **FA/FV** type

《Instruction manual》

HI-BORE Installation guide

■ Assembly precautions

The cartridge, dial screw and thrust face must be cleaned and a lubricant such as Never seez applied before use. Please ensure that the unit is free from dust during assembly as this may affect the accuracy of adjustment. (Torque adjustability and thrust face condition may deteriorate.)

■ How to assemble cartridge

- ① The space between the bush and the washer is large which means that the spring force is small, therefore the torque required to turn the screw is low.
- ② Tighten the washer screw until the washer and V shaped taper touch.

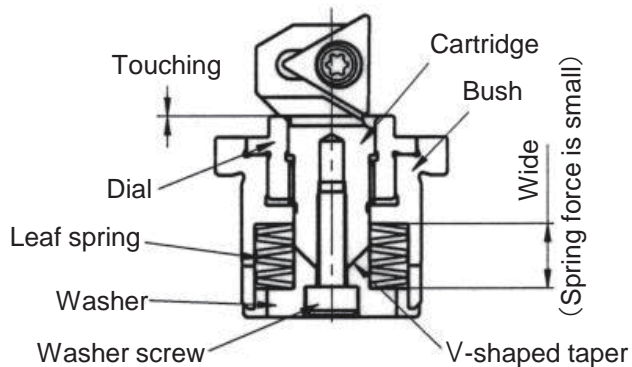

■ Recommended washer screw torque

Hi-bore size	Screw size	Recommended torque	
		N·m	kgf·m
Type 0	M2	0.49	0.05
Type 1	M2.5	0.98	0.10
Type 2	M3	2.25	0.23
Type 3	M4	5.19	0.53
Type 4	M5	10.29	1.05

■ Cartridge installation

QEJ120

Angular type(FA type)

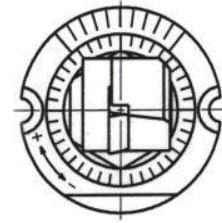

When installing the cartridge the cutting edge should be positioned towards the chamfering on the bush as shown.

Vertical type(FV type)

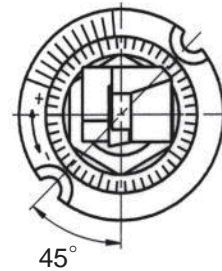

When installing the cartridge the cutting edge should be placed at 45° to the locating screws as shown.

■ Dimensional adjustment



- Dial scale FV type 50 divisions
 FA type 40 divisions
- 1 division on the inner scale corresponds to a radius increase of 0.01mm.
- 1 division on the inner scale corresponds to a radius increase of 0.001mm.
- Turn the dial clockwise to extend the Hi-bore and increase the hole diameter.

■ Cautions

Please exchange the consumable parts such as the clamping levers ahead of time. Moreover, please request the overhaul to the manufacturer when accuracy has decreased.