

Inclined cutting edge insert

# **BAP** *series*

A highly rigid body and low cutting resistance inserts

## Realize stable machining.

Due to a moulded breaker with a positive rake angle,

■ **Low cutting resistance and good chip disposal.**

Because of thicker insert's backing metal than existing products,

■ **Highly rigid body.**

With a wiper edge,

■ **An excellent surface finish.**



# Inclined cutting edge insert

# BAP series

## Features

### Low cutting resistance

A positive rake angle and a molded chipbreaker gives low cutting resistance, good sharpness and excellent chip disposal.

Geometry	$\alpha^\circ$	$\beta^\circ$
H breaker	12	5
M · G breaker	15 - 20	15

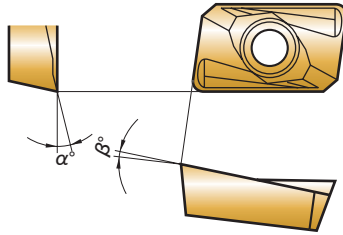

### High rigidity

Compared to the conventional type, the backing metal of the insert seat is thicker for improved rigidity.

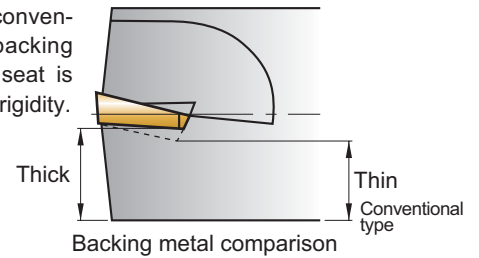

### High finishing accuracy

The use of a wiper edge produces an excellent surface finish.

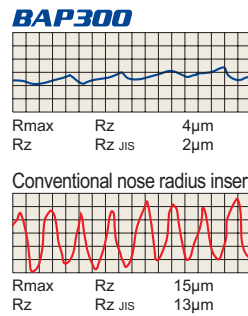
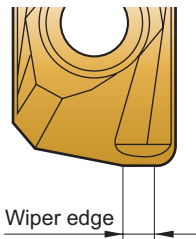

### A variety of grades & geometries

Three chipbreakers available in coated carbide, cermet or cemented carbide allow for the machining of a wide range of workpiece materials.

**H breaker**



Coated carbide  
Cermet  
Carbide

**M breaker**



Coated carbide  
Cermet

**G breaker**



Carbide

### Application guideline

Workpiece	Finishing			Roughing		
	Stable cutting	General cutting	Unstable cutting	Stable cutting	General cutting	Unstable cutting
Mild steel Carbon steel Alloy steel	NX4545	F7030		F7030		
	M breaker		H breaker	M breaker		H breaker
Hardened steel	NX4545	VP15TF		VP15TF		
	M breaker			M breaker		
Stainless steel	NX4545	F7030		F7030		
	M breaker		H breaker	M breaker		H breaker
Cast iron Ductile cast iron	VP15TF			VP15TF		
	M breaker			M breaker		
Aluminium alloy	HTi10			HTi10		
	G breaker			G breaker		
Titanium alloy	HTi10			HTi10		
	G breaker			G breaker		
Heat resistant alloy	F7030			F7030		
	M breaker			M breaker		

1) The grades shown above are the main grades. For more details refer to insert standards (page 4) and recommended cutting conditions (page 5).

2) Stable cutting (low depth of cut, low feed rate, machining without scale, and machining with a high rigidity machine) Unstable cutting (large depth of cut, high feed rate, machining with scaling, interrupted cutting, and machining with a low rigidity machine.)

# BAP series

Shank type

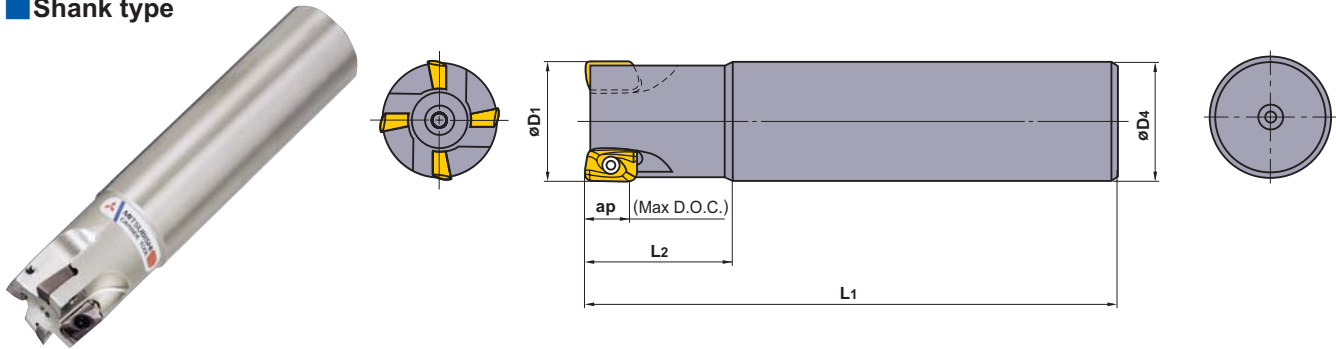

Right hand tool holder only.

Type	Order number	Stock	Number of teeth	Dimensions (mm)					Insert	Clamp screw	Wrench
				D1	L1	D4	L2	ap			
Standard type	<b>BAP300R101S16</b>	●	1	10	85	16	25	9	APG/MT1135 PDER-○○	TS25	TKY08F
	<b>121S16</b>	●	1	12	85	16	25	9		TS25	TKY08F
	<b>141S16</b>	●	1	14	85	16	25	9		TS25	TKY08F
	<b>162S16</b>	●	2	16	85	16	25	9		TS25	TKY08F
	<b>182S16</b>	●	2	18	85	16	25	9		TS25	TKY08F
	<b>203S20</b>	●	3	20	100	20	30	9		TS25	TKY08F
	<b>223S20</b>	●	3	22	100	20	30	9		TS25	TKY08F
	<b>254S25</b>	●	4	25	115	25	35	9		TS25	TKY08F
	<b>284S25</b>	●	4	28	115	25	35	9		TS25	TKY08F
	<b>304S32</b>	●	4	30	125	32	45	9		TS25	TKY08F
	<b>325S32</b>	●	5	32	125	32	45	9		TS25	TKY08F
	<b>406S32</b>	●	6	40	125	32	45	9		TS25	TKY08F
	<b>507S32</b>	●	7	50	125	32	45	9		TS25	TKY08F
	<b>638S32</b>	●	8	63	125	32	45	9		TS25	TKY08F
Long shank type	<b>BAP300R202LS20</b>	●	2	20	150	20	60	9	APG/MT1135 PDER-○○	TS25	TKY08F
	<b>253LS25</b>	●	3	25	170	25	70	9		TS25	TKY08F
	<b>323LS32</b>	●	3	32	190	32	90	9		TS25	TKY08F
	<b>403LS32</b>	●	3	40	190	32	90	9		TS25	TKY08F
Standard type	<b>BAP400R252S25</b>	●	2	25	115	25	35	14	APG/MT1604 PDER-○○	TS4	TKY15F
	<b>323S32</b>	●	3	32	125	32	45	14		TS43	TKY15F
	<b>404S32</b>	●	4	40	125	32	45	14		TS43	TKY15F
	<b>505S32</b>	●	5	50	125	32	45	14		TS43	TKY15F
	<b>636S32</b>	●	6	63	125	32	45	14		TS43	TKY15F

● : Inventory maintained.

# BAP series

## Shank type (long cutting edge)

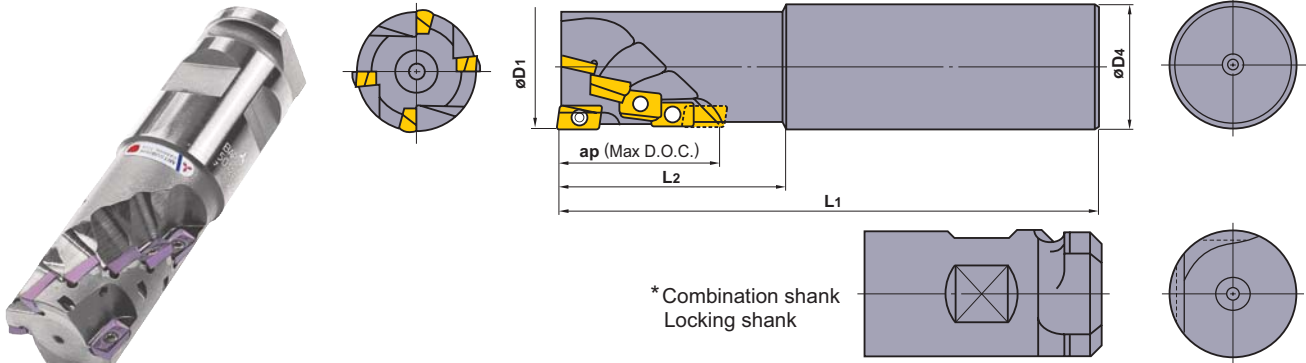

Right hand tool holder only.

Order number	Stock R	Number of teeth	Dimensions (mm)					Number of flutes	Insert	Clamp screw	Wrench
			D1	L1	D4	L2	ap				
<b>BAP300R2004ES20</b>	●	4	20	120	20	40	25	1 APG/MT1135 PDER-○1/○2	TS25	TKY08F	
<b>2508ES25</b>	●	8	25	130	25	50	34				
<b>3212ES32</b>	●	12	32	140	32	60	43				
<b>4014ES42</b>	●	14	40	150	42	70	51				
<b>BAP400R4008ES42</b>	●	8	40	150	42	70	53	2 APG/MT1604 PDER-○1/○2	TS43	TKY15F	
<b>5012ES58</b>	●	12	50	175	50.8	90	66				

## Arbor type (long cutting edge)

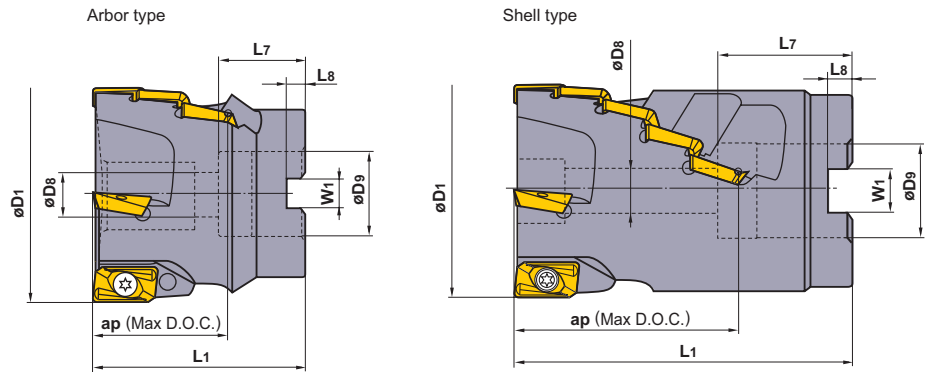

Right hand tool holder only.

Type	Order number	Stock R	Number of teeth	Dimensions (mm)							Number of flutes	Insert	Clamp screw	Wrench
				D1	L1	D9	L7	D8	W1	L8				
Arbor type	<b>BAP400R06308C</b>	●	8	63	63	25.4	26	13	9.5	6	40	2 APG/MT1604 PDER-○1/○2	TS43	TKY15F
	<b>08012D</b>	●	12	80	63	31.75	32	17	12.7	8	40			
Shell type	<b>BAP400R06312A27</b>	□	12	63	100	27	40	13	12.4	7	66			
	<b>08018A27</b>	□	18	80	100	27	40	13	12.4	7	66			

Note : Only inserts with corner radius of 0.4mm or 0.8mm (H1,H2,M2) can be used for the shank type BRP400.

● : Inventory maintained. □ : Non stock, produced to order only. No mark : Not manufactured.

▲ : Inventory maintained. To be replaced by new products.



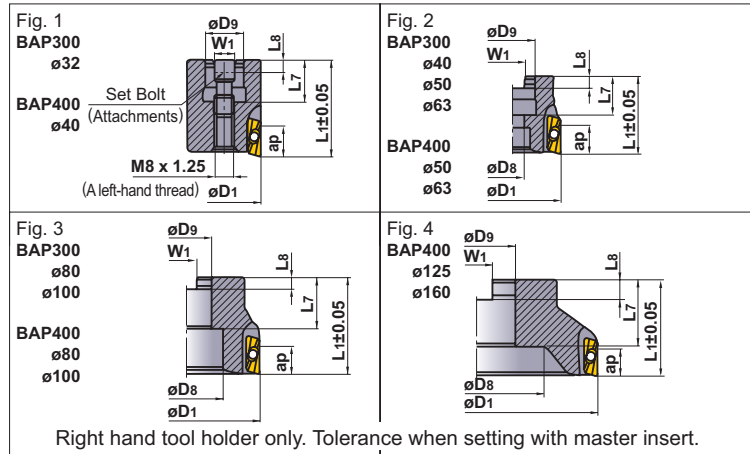

With coolant holes

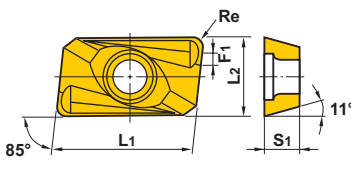

Light Alloy	Cast Iron	General Steel	Stainless Steel	Hardened Steel
➔				

Order number	Stock	Number of teeth	Dimensions (mm)								Tool weight (kg)	Max. depth of cut ap	Clamp screw	Set Bolt	Wrench	Type
			D1	L1	D9	L7	D8	W1	L8							
BAP300	BAP300-032A05R	●	5	32	40	16	18	—	8.4	5.6	0.2	9	TS25	※ LS24	①TKY08F	Fig. 1
	-040A06R	●	6	40	40	16	18	9	8.4	5.6	0.3	9	TS25	※ LS24	①TKY08F	Fig. 2
	-050A07R	●	7	50	40	22	20	11	10.4	6.3	0.4	9	TS25	※ LS24	①TKY08F	Fig. 2
	-063A08R	●	8	63	40	22	20	11	10.4	6.3	0.7	9	TS25	※ LS24	①TKY08F	Fig. 2
	R0309C	●	9	80	50	25.4	26	38	9.5	6.0	1.1	9	TS25	※ LS24	①TKY08F	Fig. 3
	R0411D	●	11	100	50	31.75	32	45	12.7	8.0	1.6	9	TS25	※ LS24	①TKY08F	Fig. 3
BAP400	BAP400-040A04R	●	4	40	40	16	18	—	8.4	5.6	0.3	14	TS43	※ LS24	①TKY15F	Fig. 1
	-050A05R	●	5	50	40	22	20	11	10.4	6.3	0.4	14	TS43	※ LS24	①TKY15F	Fig. 2
	-063A06R	●	6	63	40	22	20	11	10.4	6.3	0.6	14	TS43	※ LS24	①TKY15F	Fig. 2
	R0307C	●	7	80	50	25.4	26	38	9.5	6.0	1.0	14	TS43	※ LS24	①TKY15F	Fig. 3
	R0408D	●	8	100	50	31.75	32	45	12.7	8.0	1.6	14	TS43	※ LS24	①TKY15F	Fig. 3
	R0509E	●	9	125	50	38.1	35	68	15.9	10	2.3	14	TS43	—	②TKY15D	Fig. 4
	R0610E	●	10	160	50	38.1	35	72	15.9	10	4.0	14	TS43	—	②TKY15D	Fig. 4

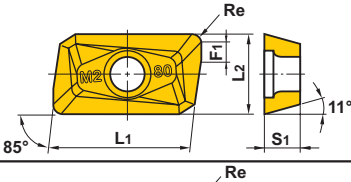
Insert

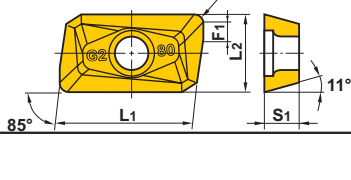
Shape	Cutter Type	Order number	Class	Coated						Cermet	Carbide	Geometry	Dimensions (mm)				
				F7030	F620	VP15TF	UP20M	NX2525	NX4545				UT120T	HT110	L1	L2	S1
	BAP300	APMT1135PDER-H1	M	●	▲	●	●	●	●	●	●		11	6.35	3.5	1.5	0.4
		1135PDER-H2	M	●	▲	●	●	●	●	●	●		11	6.35	3.5	1.2	0.8
		1135PDER-H3	M	●	▲	●	●	●	●	●	●		11	6.35	3.5	0.8	1.2
		1135PDER-H4	M	●	▲	●	●	●	●	●	●		11	6.35	3.5	0.4	1.6
		1135PDER-H6	M	●	▲	●	●	●	●	●	●		11	6.35	3.5	0.4	2.4
	BAP400	APMT1604PDER-H1	M	●	▲	●	●	●	●	●	●		16.5	9.525	4.76	1.7	0.4
		1604PDER-H2	M	●	▲	●	●	●	●	●	●		16.5	9.525	4.76	1.4	0.8
		1604PDER-H4	M	●	▲	●	●	●	●	●	●		16.5	9.525	4.76	0.4	1.6
	BAP300	APMT1135PDER-M0	M	●	●	●	●	●	●	●	●		11	6.35	3.5	1.8	0.2
		1135PDER-M1	M	●	●	●	●	●	●	●	●		11	6.35	3.5	1.5	0.4
		1135PDER-M2	M	●	▲	●	●	●	●	●	●		11	6.35	3.5	1.2	0.8
	BAP400	APMT1604PDER-M2	M	●	▲	●	●	●	●	●	●		16.5	9.525	4.76	1.4	0.8
	BAP300	APGT1135PDFR-G2	G							●		11	6.35	3.5	1.2	0.8	
		BAP400	APGT1604PDFR-G2	G								●	16.5	9.525	4.76	1.4	0.8

## Recommended cutting conditions

### ● Standard type

Workpiece	Hardness	Grade	Breaker	Cutting mode	Cutting speed (m/min)	Feed per tooth (mm/tooth)	
P Mild steel (JIS SS400, S10C etc.)  Carbon steel Alloy steel (JIS S45C, JIS SCM440 etc.)	≤ 180HB	NX4545	H	Finishing	160 (120-180)	0.1 (0.05-0.15)	
		F7030	M	General	180 (150-200)	0.15 (0.1-0.2)	
	180-280HB	NX4545	H	Finishing	120 (100-160)	0.08 (0.05-0.1)	
		F7030	M	General	150 (120-200)	0.15 (0.1-0.2)	
		UTi20T·UP20M	H	General	120 (100-160)	0.2 (0.1-0.25)	
		F7030	H	Unstable	120 (100-160)	0.15 (0.1-0.2)	
		280-350HB	NX4545	H	Finishing	100 (80-120)	0.08 (0.05-0.1)
			F7030	M	General	140 (120-160)	0.15 (0.1-0.2)
	M Stainless steel (JIS SUS304 etc.)	≤ 200HB	F7030	M	General	140 (120-160)	0.15 (0.1-0.2)
UTi20T·UP20M			H	General	120 (80-140)	0.1 (0.05-0.15)	
F7030			H	Unstable	120 (80-140)	0.2 (0.1-0.25)	
K Cast iron (JIS FC250 etc.)  Ductile cast iron (JIS FCD450 etc.)  Ductile cast iron (JIS FCD500 etc.)	Tensile strength ≤ 350N/mm <sup>2</sup>	VP15TF	M	General	140 (120-160)	0.15 (0.1-0.2)	
		HTi10·UTi20T	H	General	120 (100-140)	0.2 (0.1-0.25)	
	Tensile strength ≤ 450N/mm <sup>2</sup>	VP15TF	M	General	120 (100-140)	0.15 (0.1-0.2)	
		HTi10·UTi20T	H	General	100 (80-120)	0.2 (0.1-0.25)	
	Tensile strength 500-800N/mm <sup>2</sup>	VP15TF	M	General	100 (80-120)	0.1 (0.05-0.15)	
		HTi10·UTi20T	H	General	80 (60-100)	0.15 (0.1-0.2)	
H Quenched steel	≥ 40HRC	VP15TF	M	General	70 (50-100)	0.1 (0.05-0.15)	
S Titanium alloy	≥ 350HB	HTi10	G	General	40 (30-60)	0.2 (0.1-0.3)	
Heat resistant alloy	-	F7030	M	General	30 (20-40)	0.15 (0.1-0.2)	
N Aluminium alloy	-	HTi10	G	General	500 (200-1000)	0.2 (0.1-0.3)	

### ● Long cutting edge type

Workpiece	Hardness	Grade	Breaker	Cutting mode	Cutting speed (m/min)	Feed per tooth (mm/tooth)	
P Mild steel (JIS SS400, S10C etc.)  Carbon steel Alloy steel (JIS S45C, JIS SCM440 etc.)	≤ 180HB	F7030	M	General	180 (150-200)	0.15 (0.08-0.2)	
		180-280HB	F7030	M	General	150 (120-280)	0.15 (0.08-0.2)
	UTi20T·UP20M		H	General	120 (100-160)	0.15 (0.08-0.2)	
	F7030		H	Unstable	120 (100-160)	0.2 (0.1-0.25)	
	280-350HB		F7030	M	General	140 (120-160)	0.1 (0.05-0.15)
			F7030	H	Unstable	100 (80-120)	0.15 (0.08-0.2)
	M Stainless steel (JIS SUS304 etc.)		≤ 200HB	F7030	M	General	140 (120-160)
		UTi20T·UP20M		H	General	120 (80-140)	0.1 (0.08-0.15)
		F7030		H	Unstable	120 (80-140)	0.15 (0.08-0.2)
K Cast iron (JIS FC250 etc.)  Ductile cast iron (JIS FCD450 etc.)  Ductile cast iron (JIS FCD450 etc.)	Tensile strength ≤ 350N/mm <sup>2</sup>	VP15TF	M	General	140 (120-160)	0.15 (0.08-0.2)	
		HTi10·UTi20T	H	General	120 (100-140)	0.1 (0.05-0.15)	
	Tensile strength ≤ 450N/mm <sup>2</sup>	VP15TF	M	General	120 (100-140)	0.1 (0.05-0.15)	
		HTi10·UTi20T	H	General	100 (80-120)	0.15 (0.08-0.2)	
	Tensile strength 500-800N/mm <sup>2</sup>	VP15TF	M	General	100 (80-120)	0.08 (0.05-0.1)	
		HTi10·UTi20T	H	General	80 (60-100)	0.1 (0.05-0.15)	
H Quenched steel	≥ 40HRC	VP15TF	M	General	70 (50-100)	0.08 (0.05-0.1)	
S Titanium alloy	≥ 350HB	HTi10	G	General	40 (30-60)	0.15 (0.05-0.25)	
		Heat resistant alloy	-	F7030	M	General	30 (20-40)
N Aluminium alloy	-	HTi10	G	General	500 (200-1000)	0.15 (0.05-0.25)	

● Revolution (min<sup>-1</sup>) = (1000 x Cutting Speed) x (3.14 x ØD<sub>1</sub>)

● Table Feed (mm/min) = Feed per Tooth x Number of Teeth x Cutter Revolution

Cutting performance

BAP300

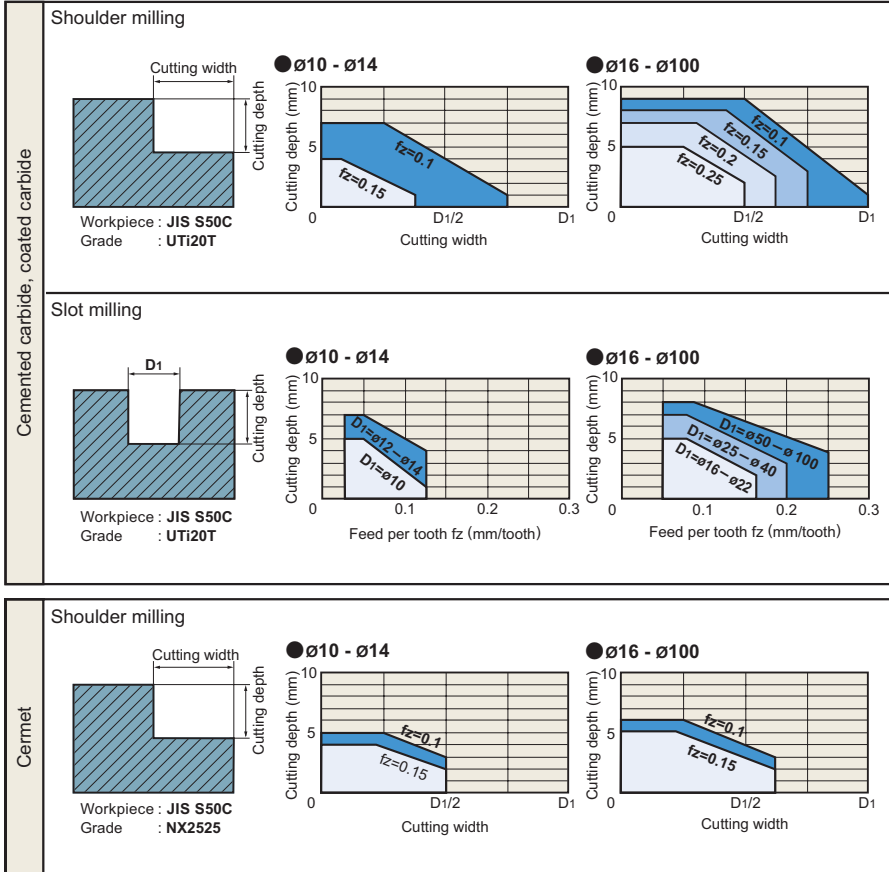

BAP400

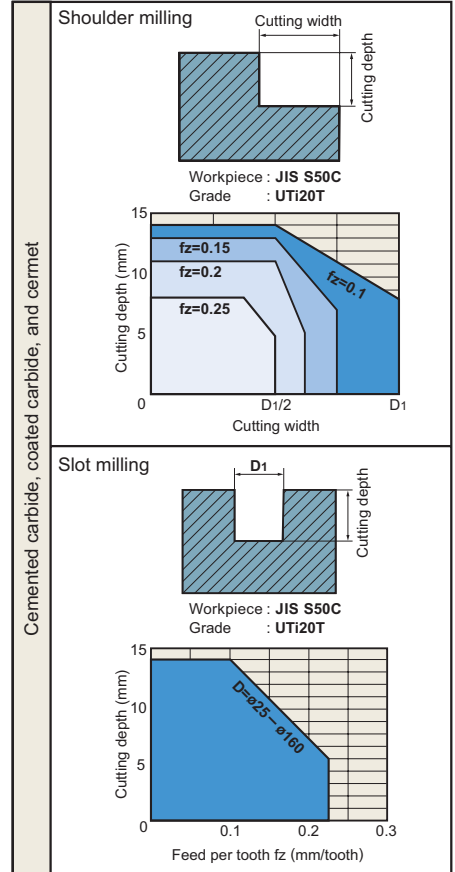

BAP300 (Long cutting edge type)

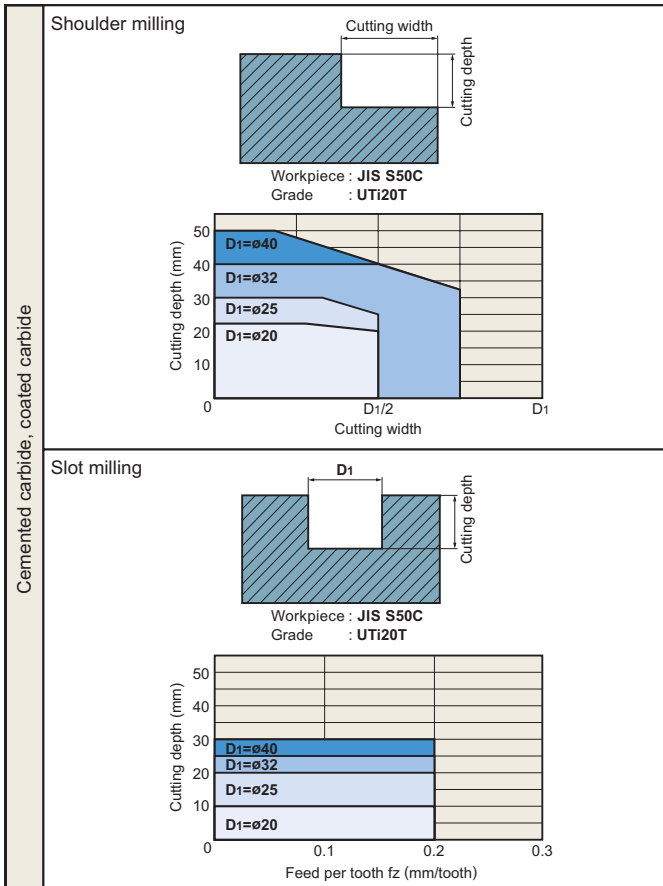

BAP400 (Long cutting edge type)

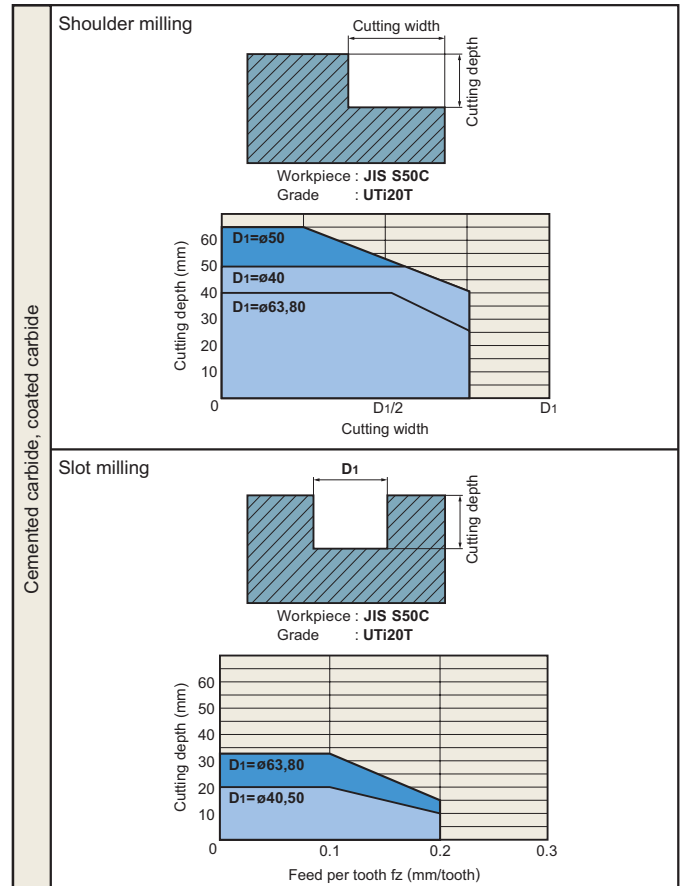

NOTE : 1) The above data was conducted on carbon steel (JIS S50C). For use with alloy steels reduce the conditions by 20 - 30%.  
 2) When slot milling, the use of an airblower is recommended.  
 3) The dimension (D1) represents the dimension at the tools peripheral cutting edge.

# BAPseries

## Application examples

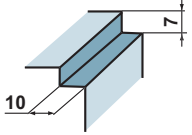
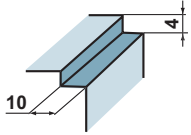
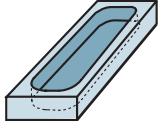
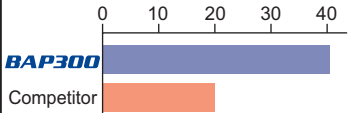
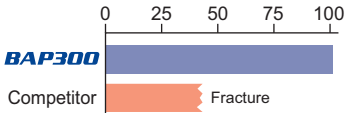
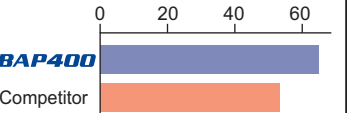
Tool	BAP300R254S25	BAP300R203S20	BAP400R252S25
Insert	APMT1135PDER-H1	APMT1135PDER-M2	APGT1604PDFR-G2
Grade	VP15TF	F7030	HTi10
Workpiece	JIS SKD61 (40HRC) 	JIS SCM440 (200HB) 	Aluminium alloy (A7075) 
Component	Machine parts	Machine parts	Machine parts
Cutting conditions	Cutting speed (m/min)	122	238
	Feed (mm/tooth)	0.1	0.1
	Depth of cut (mm)	ap = 7 ae = 10	ap = 4 ae = 10
Coolant	Airblow	Dry cutting	Dry cutting
Results	<p>● Tool life</p> <p>No. of pieces/corner</p> 	<p>● Tool life</p> <p>Cutting time (min)</p> 	<p>● Tool life</p> <p>No. of pieces/corner</p> 

For Your Safety

● Don't touch breakers and chips without gloves. ● Please machine within recommended application range, and exchange expired tools with new parts in advance. ● Please use safety cover and wear safety glasses. ● When using compounded cutting oils, please take fire prevention. ● When attaching chips or spare parts, please use the attached wrench or spanner. ● When using tools in revolution machining, please make a trial run to check run-out, vibration, abnormal sounds etc.

## MITSUBISHI MATERIALS CORPORATION



**Overseas Operations Center :**  
**Cutting Tools**

KFC bldg., 7F, 1-6-1, Yokoami, Sumida-ku, Tokyo 130-0015, Japan  
TEL 81-3-5819-8771 FAX 81-3-5819-8774

**MMC HARTMETALL GmbH**

Comeniusstr.2, 40670, Meerbusch GERMANY  
TEL 49-2159-9189-0 FAX 49-2159-50462

**MITSUBISHI MATERIALS U.S.A. CORPORATION**  
**Headquarters**

17401, Eastman Street, Irvine, California, 92614, USA  
TEL 1-949-862-5100 FAX 1-949-862-5180

**MMC METAL SINGAPORE PTE LTD.**

10, Arumugam Road, #04-00 Lion Industrial Bldg., 409957, SINGAPORE  
TEL 65-6743-9370 FAX 65-6749-1469

**Mitsubishi Carbides Home page : <http://www.mitsubishicarbide.com>**  
(Tools specifications subject to change without notice.)