



Tsukuba Plant
ISO 9001-1994
Registration No. JSAQ 080
Gifu Plant
ISO 9001-1994
Registration No. JSAQ 094



Tsukuba Plant
ISO 14001-1996
Registration No. JSAE 036

Face milling cutter for aluminium alloy

BF407 type

The One Cutter System for Aluminum Milling.

Features of **BF407** type

- Excellent welding resistance
- High performance machining
- Eliminate insert relapping
- Eliminate cutter setting
- Uses inexpensive PCD wiper blade
- Carbide inserts are polished to resist chip welding



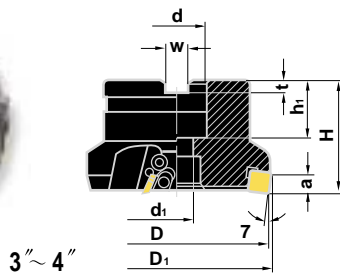

3" ~ 4"

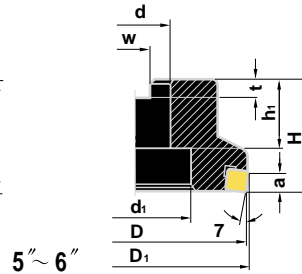

5" ~ 6"

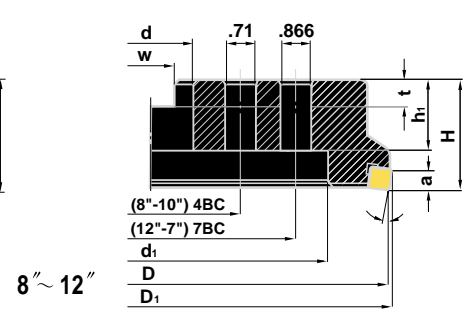

8" ~ 12"

| Al Alloy | Cast Iron | Steel | Stainless Steel | Tempered Steel |
|----------|-----------|-------|-----------------|----------------|
| ↔ | | | | |

BF407

Right hand shown

| Type | Order Number | Stock | No. of teeth | Dimensions (inch) | | | | | | | | | WEIGHT LBS. |
|-------|--------------|-------|--------------|-------------------|----------------|-------|-------|----------------|----------------|------|------|------|-------------|
| | | | | D | D ₁ | H | d | h ₁ | d ₁ | w | t | a | |
| BF407 | BF407R0305C | + | 5 | 3.14 | 3.26 | 1.969 | 1 | 1.02 | .51 | .374 | .236 | .35 | 2.4 |
| | BF407R0406E | + | 6 | 3.94 | 4.05 | 2.480 | 1-1/2 | 1.26 | .67 | .500 | .315 | | 5.1 |
| | BF407R0508E | + | 8 | 4.92 | 5.03 | 2.480 | 1-1/2 | 1.49 | 2.36 | .625 | .394 | | 6.2 |
| | BF407R0610F | + | 10 | 6.30 | 6.41 | 2.480 | 2 | 1.49 | 3.14 | .750 | .433 | | 11 |
| | BF407R0812M | + | 12 | 7.87 | 7.97 | 2.480 | 2-1/2 | 1.38 | 5.52 | 1.00 | .551 | | 17 |
| | BF407R1016M | + | 16 | 9.84 | 9.94 | 2.480 | 2-1/2 | 1.38 | 7.08 | 1.00 | .551 | | 29 |
| | BF407R1218M | + | 18 | 12.40 | 12.51 | 2.480 | 2-1/2 | 1.57 | 9.64 | 1.00 | .551 | 53.5 | |

INSERT

Aluminum and Aluminum Alloys

| Shape | Class | Order Number | Dimensions (inch) | | | | Uncoated Diamond | |
|-------|-------|--------------------|-------------------|-----|------|------------|------------------|-------|
| | | | I.C. | T | f | Max d.o.c. | HTi10 | MD220 |
| | C | NP-WFC42ZFER2 | 1/2 | 1/8 | .093 | .098 | | + |
| | | NP-WFC42ZFER6 | | | .240 | .098 | | + |
| | C | WFC42ZFER2 | 1/2 | 1/8 | .093 | .187 | | + |
| | | SFCN42ZFFR2 | 1/2 | 1/8 | .093 | .350 | + | |
| | C | SFCN42ZFFR2 | 1/2 | 1/8 | .093 | .118 | + | + |
| | | SFCN42ZFFRU (wave) | 1/2 | 1/8 | .093 | .312 | | + |

| Material | Silicon | Grade | SFM | I.P.T. |
|----------|---------|-------|-----------|-----------|
| 1070 | 2% | HTi10 | 1300-3200 | .004-.010 |
| 6061 | | MD220 | 2600-3900 | .002-.010 |
| 4032 | 10-13% | HTi10 | 1300-3200 | .002-.006 |
| | | MD220 | 2600-3900 | .002-.010 |
| 390 | 13-15% | HTi10 | 650-1900 | .002-.010 |
| | | MD220 | 1300-2600 | .002-.010 |

SPARE PARTS



| Spare Parts | | | | | |
|--------------------|----------------|------------|-------------|-----------------|--------|
| Milling Cutter No. | | Wedge | Wedge Screw | Adjusting Screw | Wrench |
| BF407R Type | 0305C | CWSF407TR1 | LS15T | CAS51T | TKY25T |
| | 0406E | | | | |
| | 0508E 0812M | CWSF407TR2 | | | |

+ + + : Stock,
 + + : Non Stock,
 : Not Produced

MITSUBISHI MATERIALS U.S.A. CORPORATION

17401 Eastman Street, Irvine, California 92614, U.S.A
 TEL. (800) 621-4486 FAX. (800) 643-4909
 Customer Service: (800) 523-0800 Technical Support: (800) 486-2341
 Chicago Branch Office: 5999 New Wilke Rd, Suite 200, Rolling Meadows, Illinois U.S.A. 60008
 TEL. 847-806-1550 FAX. 847-806-1563
 Detroit Branch Office: 39303 Country Club Drive, Suite A-1, Farmington Hills, Michigan 48331
 TEL. 248-489-1000 FAX. 248-489-3008
 Toronto Branch Office: 6535 Millcreek Drive, Unit 63 & 64, Mississauga, Ontario, Canada L5N 2M2
 TEL. 905-814-0240 FAX. 905-814-0245

MMC METAL DE MEXICO SA. DE C.V.

Av. Alvaro Obregon #406, Col. Alameda, 38040 Celaya, GTO. Mexico
 TEL. 011-52-461-39493 FAX. 011-52-461-29863