



Tsukuba Plant
ISO 9001-1994
Registration No. JSAQ 080
Gifu Plant
ISO 9001-1994
Registration No. JSAQ 094



Tsukuba Plant
ISO 14001-1996
Registration No. JSAE 036

Face milling cutter for aluminium alloy

BF407 type

The One Cutter System for Aluminum Milling.

Features of **BF407** type

- Excellent welding resistance
- High performance machining
- Eliminate insert relapping
- Eliminate cutter setting
- Uses inexpensive PCD wiper blade
- Carbide inserts are polished to resist chip welding



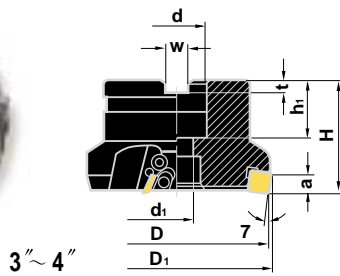

3" ~ 4"

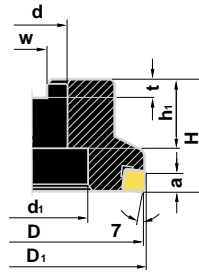

5" ~ 6"

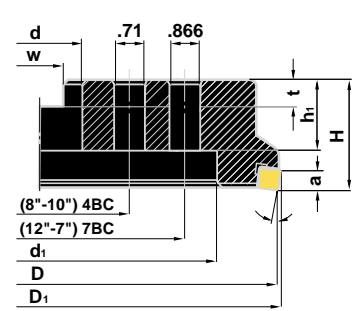

8" ~ 12"

Al Alloy	Cast Iron	Steel	Stainless Steel	Tempered Steel
← →				

BF407

Right hand shown

Type	Order Number	Stock	No. of teeth	Dimensions (inch)									WEIGHT LBS.
				D	D ₁	H	d	h ₁	d ₁	w	t	a	
BF407	BF407R0305C	+	5	3.14	3.26	1.969	1	1.02	.51	.374	.236	.35	2.4
	BF407R0406E	+	6	3.94	4.05	2.480	1-1/2	1.26	.67	.500	.315		5.1
	BF407R0508E	+	8	4.92	5.03	2.480	1-1/2	1.49	2.36	.625	.394		6.2
	BF407R0610F	+	10	6.30	6.41	2.480	2	1.49	3.14	.750	.433		11
	BF407R0812M	+	12	7.87	7.97	2.480	2-1/2	1.38	5.52	1.00	.551		17
	BF407R1016M	+	16	9.84	9.94	2.480	2-1/2	1.38	7.08	1.00	.551		29
	BF407R1218M	+	18	12.40	12.51	2.480	2-1/2	1.57	9.64	1.00	.551	53.5	

INSERT

Aluminum and Aluminum Alloys

Shape	Class	Order Number	Dimensions (inch)				Uncoated Diamond	
			I.C.	T	f	Max d.o.c.	HTi10	MD220
	C	NP-WFC42ZFER2	1/2	1/8	.093	.098		+
		NP-WFC42ZFER6			.240	.098		+
	C	WFC42ZFER2	1/2	1/8	.093	.187		+
		SFCN42ZFFR2	1/2	1/8	.093	.350	+	
		SFCN42ZFER2				.118		+
		SFCN42ZFFRU (wave)	1/2	1/8	.093	.312		+

Material	Silicon	Grade	SFM	I.P.T.
1070	2%	HTi10	1300-3200	.004-.010
6061		MD220	2600-3900	.002-.010
4032	10-13%	HTi10	1300-3200	.002-.006
		MD220	2600-3900	.002-.010
390	13-15%	HTi10	650-1900	.002-.010
		MD220	1300-2600	.002-.010

SPARE PARTS



Spare Parts		①	②	③	
Milling Cutter No.		Wedge	Wedge Screw	Adjusting Screw	Wrench
BF407R Type	0305C	CWSF407TR1	LS15T	CAS51T	TKY25T
	0406E				
	0508E 0812M				

+ + + : Stock,
 : Non Stock,
 : Not Produced

MITSUBISHI MATERIALS U.S.A. CORPORATION

17401 Eastman Street, Irvine, California 92614, U.S.A

TEL. (800) 621-4486 FAX. (800) 643-4909

Customer Service: (800) 523-0800

Technical Support: (800) 486-2341

Chicago Branch Office: 5999 New Wilke Rd, Suite 200, Rolling Meadows, Illinois U.S.A. 60008

TEL. 847-806-1550 FAX. 847-806-1563

Detroit Branch Office: 39303 Country Club Drive, Suite A-1, Farmington Hills, Michigan 48331

TEL. 248-489-1000 FAX. 248-489-3008

Toronto Branch Office: 6535 Millcreek Drive, Unit 63 & 64, Mississauga, Ontario, Canada L5N 2M2

TEL. 905-814-0240 FAX. 905-814-0245

MMC METAL DE MEXICO SA. DE C.V.

Av. Alvaro Obregon #406, Col. Alameda, 38040 Celaya, GTO. Mexico

TEL. 011-52-461-39493

FAX. 011-52-461-29863